



REPLACEMENT PARTS LIST

Inverter Single Zone Ductless Mini-Split

B-ZHP06SA-1

EXPLODED VIEW

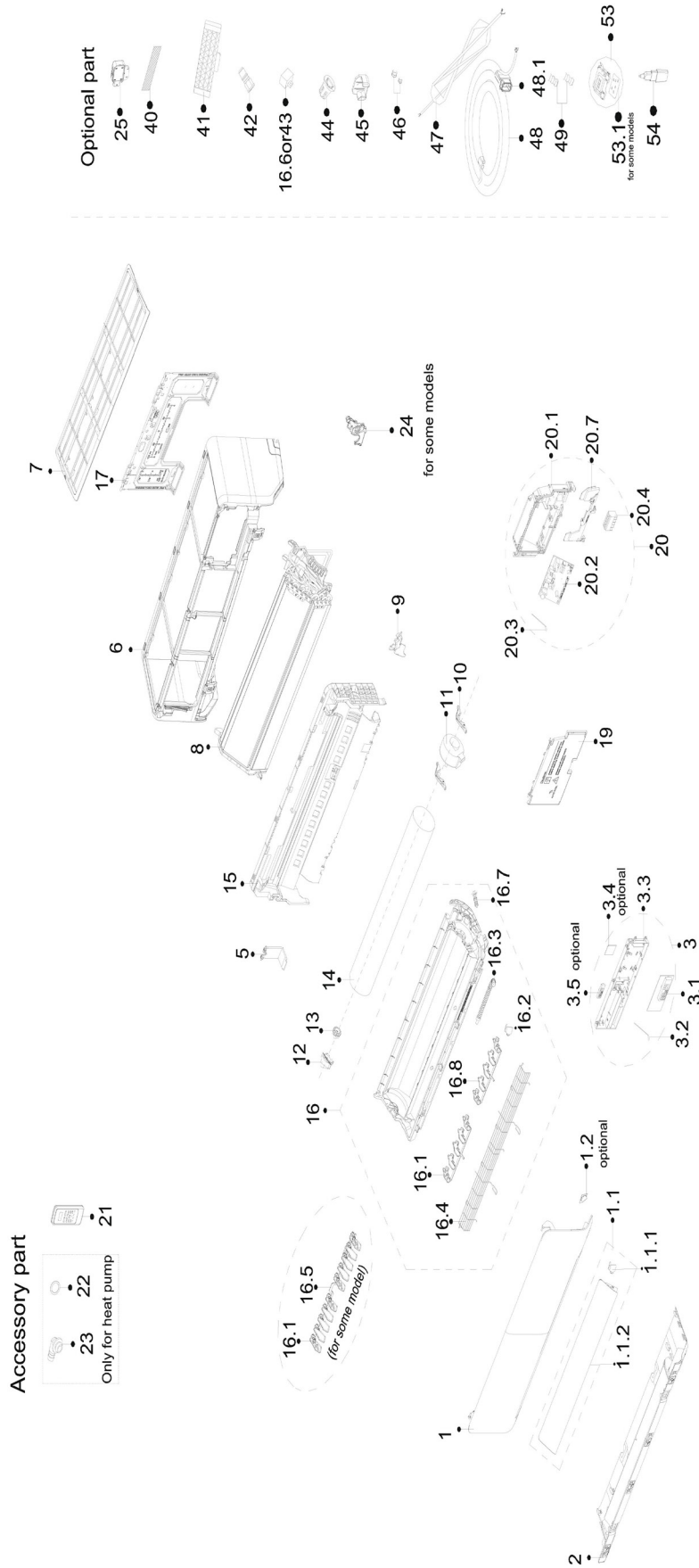

REPLACEMENT PARTS

Location	Part Name	Quantity	Part No.
1	Panel assembly	1.0	12122000027561
1.1	Panel assembly	1.0	12122000027562
1.1.1	Stepper motor	1.0	11002010001446
1.1.2	Horizontal louver	1.0	12122000027035
2	Panel assembly	1.0	12122000027037
3	Display box assembly	1.0	17222000044153
3.1	Display board assembly	1.0	17122000062305
3.2	Ambient temperature sensor subassembly	1.0	11201007003103
3.3	Display box	1.0	12122000026921
3.5	adapter board subassembly	1.0	17122000063852
5	Chassis supporter	1.0	12122000026621
6	Panel frame assembly	1.0	12122000027027
7	Air filter	1.0	12122000027040
8	evaporator assembly	1.0	15822000015826
9	Pipe clamp board	1.0	12122000027026
10	Fixing plate for fan motor	2.0	12122000011994
11	Motor	1.0	11002015021815
12	bearing holder	1.0	12122000000350
13	bearing base	1.0	12622000000131
14	Cross flow fan	1.0	12100102000131
15	Chassis assemble((above))	1.0	12122000027029
16	Chassis assemble((below))	1.0	12122000027682
16.1	louver	6.0	12122000026617
16.2	Stepper motor	1.0	11002010001486
16.3	Drain pipe joint	1.0	12100501000032
16.4	Air outlet Protective wire	1.0	12222000014325
16.5	Connecting rod of louver	1.0	12122000027024
16.7	Drainage plug	1.0	12622000000030
16.8	louver	6.0	12122000026616
17	Installation plate	1.0	12222000A06971
19	Cover of electronic control box	1.0	12122000026601
20	Structural components of indoor electric control box	1.0	17222000044079
20.1	Electronic control box	1.0	12122000026606
20.2	Indoor main control board subassembly	1.0	17122000063927
20.3	Pipe temperature sensor subassembly	1.0	11201007003445
20.4	Terminal block	1.0	17400401000577
20.7	Electric control box bracket	1.0	12122000026605
21	remote controller	1.0	17317000012079
24	Ratproof plate subassembly	1.0	12122000028101
25	Gas sensor	1.0	11201003000364
40	Air freshening filter	1.0	12100204000685
42	Detection valve	1.0	15500209000001
46	Copper nut	1.0	15500406000016
46	Copper nut	1.0	15500406000010

Due to ongoing product improvements, specifications and dimensions are subject to change and correction without notice or incurring obligations. Determining the application and suitability for use of any product is the responsibility of the installer. Additionally, the installer is responsible for verifying dimensional data on the actual product prior to beginning any installation preparations.

Incentive and rebate programs have precise requirements as to product performance and certification. All products meet applicable regulations in effect on date of manufacture; however, certifications are not necessarily granted for the life of a product. Therefore, it is the responsibility of the applicant to determine whether a specific model qualifies for these incentive/rebate programs.

Comfort-Cire[®]  **Century**[®]

1900 Wellworth Avenue • Jackson, MI 49203 • 517-787-2100



REPLACEMENT PARTS LIST

Inverter Single Zone Ductless Mini-Split

A-ZHP06SA-1

EXPLODED VIEW

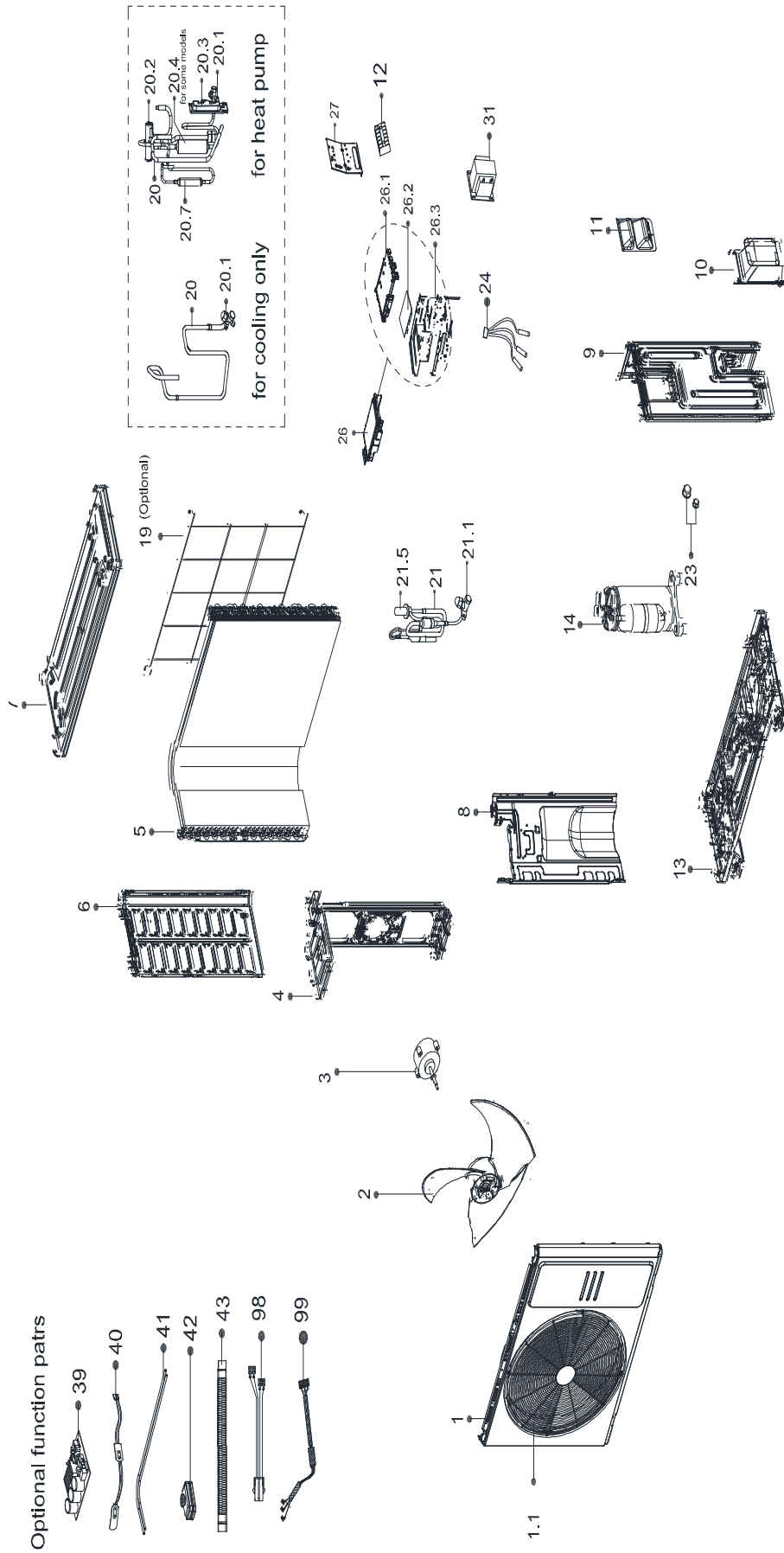

REPLACEMENT PARTS

Location	Part Name	Quantity	Part No.
1	Front panel assembly	1.0	12222000A06282
1.1	Air outlet grille	1.0	12222000A06092
2	axial flow fan	1.0	12100105000841
3	Motor	1.0	11002015016275
4	Motor bracket	1.0	12222000012371
5	Condenser assembly	1.0	15822000015846
6	Left supporter	1.0	12222000013472
7	Top cover	1.0	12222200005737
8	Partition board	1.0	12222000019785
9	right side plate	1.0	12222000019846
10	Water collector	1.0	12122000007150
11	handle	1.0	12222000010966
12	Terminal block	1.0	17400401006456
13	Chassis assembly	1.0	12222000014505
14	compressor	1.0	11103020014063
19	Rear Grille	1.0	12222000013085
20	4-ways valve or Gas valve assembly	1.0	15422000026107
20.1	Gas valve	1.0	15500204000665
20.2	4-way valve	1.0	15500216002683
20.3	Valve plate	1.0	12222200005738
20.4	Muffler assembly	1.0	15122000034757
20.7	Muffler assembly	1.0	15122000031742
21	High pressure valve assembly	1.0	15422000025069
21.1	High pressure valve	1.0	15500208000028
21.5	Electronic expansion valve	1.0	15500213000047
23	Copper nut	1.0	15500406000016
23	Copper nut	1.0	15500406000010
24	combination sensor	1.0	11201011001047
26	Electronic control box subassembly	1.0	17222000044080
26.1	Electronic installing box	1.0	12222000019786
26.2	main control board assembly	1.0	17122000063942
26.3	Electronic installing box assembly	1.0	12222000019767
27	Terminal board	1.0	12222000019766
31	Reactor	1.0	17400306000041
33	Outdoor unit trademark	1.0	16000201001228
40	Crankcase electric heater	1.0	17402001001499
41	Electric heater of chassis	1.0	17402002000544
99	compressor connection cable	1.0	17401203027680

Due to ongoing product improvements, specifications and dimensions are subject to change and correction without notice or incurring obligations. Determining the application and suitability for use of any product is the responsibility of the installer. Additionally, the installer is responsible for verifying dimensional data on the actual product prior to beginning any installation preparations.

Incentive and rebate programs have precise requirements as to product performance and certification. All products meet applicable regulations in effect on date of manufacture; however, certifications are not necessarily granted for the life of a product. Therefore, it is the responsibility of the applicant to determine whether a specific model qualifies for these incentive/rebate programs.



1900 Wellworth Avenue • Jackson, MI 49203 • 517-787-2100